

bürkert
FLUID CONTROL SYSTEMS

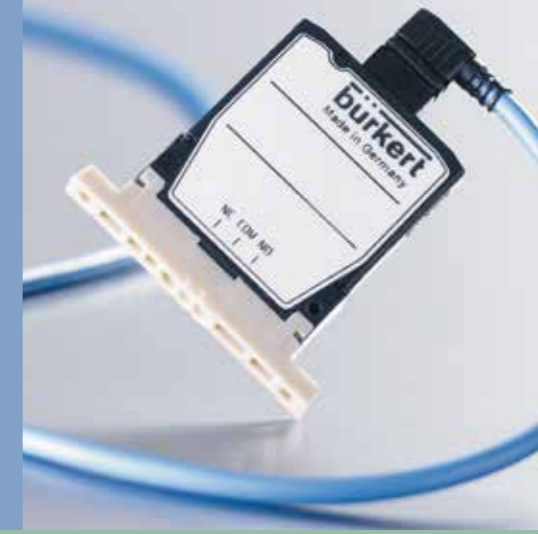

bürkert
FLUID CONTROL SYSTEMS

Product Overview MicroFluidics

Bürkert Fluid Control Systems
Christian-Bürkert-Straße 13-17
74653 Ingelfingen
Germany
Tel. +49 7940 100
Fax +49 7940 1091204
info@burkert.com
www.burkert.com

- 01 SOLENOID VALVES
- 02 PROCESS VALVES
- 03 PNEUMATICS
- 04 MEASUREENT DEVICES
- 05**
- 06 MASS FLOW CONTROLLERS
- 07 PROPORTIONAL VALVES

Content

3	Introduction
4	Fascination Bürkert
6	Microfluidic Solutions from a single source
8	MicroFluidics Characteristics
10	Accuracy, Precision and Timing
12	Time-Pressure Dosing
16	Syringe Pump Dosing
22	Volumetric Dosing
26	Valves
31	Contact

Introduction

In LifeSciences, In-Vitro Diagnostics, Medical Devices and Analytical Chemistry, the general trend is towards both the increased automation of procedures, accompanied with the miniaturization of the devices involved. This not only allows processes to be designed with considerably greater efficiency, it also opens up whole new fields of application. Bürkert with its particular product area MicroFluidics offers a product line tailored to the needs of this very specific market.

Whether it is for valves, pumps or individual system solutions, the entire product range is geared towards ensuring the controlled handling of even the smallest volumes of liquids. Depending on the requirements, different dosing principles are implemented. The devices have been designed with the following requirements foremost in mind:

- Miniaturization of the internal and external dimensions
- Modular construction taking the standard structure into account
- Quick, precise and reproducible response times
- High level of dependability
- Low power consumption

The following overview shows different dosing principles and their area of application as well as the matching products and system solutions as a supplement to the detailed data sheets available at www.burkert.com.

Our colleagues are pleased to consult you in selecting the right product or system for your application.

Welcome to the Fascinating World of Fluid Control Systems

Measurement and control: When it comes to working with liquids and gases, we are at your side – as a manufacturer of sophisticated products, as a problem-solver with an eye for the big picture, and as a partner offering you reliable advice. Since we started in 1946, we have developed into one of the world's leading suppliers of Fluid Control Systems. At the same time we have kept our status as a family-owned business with a foundation of strong basic values to highlight the way we think and act.

EXPERIENCE

There are things which are not inherently yours. You have to gather them bit by bit. You receive them from others. And you constantly have to acquire them anew. That is what makes them so valuable. Experience is one of those things. For instance, because of our many years of experience with MicroFluidics, we can provide our extensive services to you – from consulting, development, and 3D CAD simulating to testing and after-sales service. Whether individual product solutions or a pioneering new system for the entire control process: Benefit from our experience.

COURAGE

Those who only work toward optimizing things that already exist will eventually reach the limits – technically, financially, or personally. In order to overcome these limits, courage is needed: The courage to be different and trust one's own ideas; the courage to venture into the unknown, searching for new ways to develop products that have never existed before. We have this courage. By pooling and utilizing our competencies across all sectors, you benefit from our cumulative knowledge of MicroFluidic systems – whether it is in Clinical Diagnostics or Industrial Analytics.

CLOSENESS

Some things we simply take for granted. Only when they are gone, do we realize how important these things really were. This applies in particular to closeness. Without closeness, it is very difficult to build relationships and a good understanding of one another. As an established medium-sized company, we know that. And that is why we are always there for you. Working with you, we develop the best possible solutions for your projects in the area of MicroFluidics. Our global presence in 35 locations enables us to press ahead with technical innovations for our customers around the world.

Bürkert Product Program

We are one of the few suppliers on the market to cover the complete control loop. Our current product range extends from solenoid valves through process and analytical valves to pneumatic actuators and sensors.



Bürkert offers a remarkable range of servo-assisted and direct acting solenoid valves. Read more about them in this brochure.



Bürkert offers unlimited modularity for process control with angle-seat, globe and diaphragm valves in the widest range of configurations.



Here you can find our product range of pneumatic valves, valve units and automation systems as well as information on our control cabinet building.



Here you can find our sensors, transmitters and controllers for measuring and controlling flow, temperature, pressure, level, pH/ORP and conductivity.



The brochure contains an overview of Bürkert miniature valves and micro pumps, which allow for precise and safe handling of small volumes of liquids.



This brochure provides technical background information as well as a detailed product overview for the mass flow controller and meter product range.



This brochure presents our proportional valves including their respective features, functions and typical applications.



Microfluidic Solutions from a single source

Range of manufacture with know-how

We offer you a complete performance spectrum. Everything from choosing the right product to consulting, engineering, production and commissioning.

Take advantage of our competence in production and development. Our qualified engineers work continuously on the optimisation of fluid technology. Our high degree of vertical diversification allows us to respond to special customer requirements and to produce components quickly and independently.



Coil manufacture

At the Gerabronn factory.

We wind, mould and inspect our coils ourselves. This independence ensures complete quality control and traceability of the solenoid valve production. Our coiling machines are capable of winding wires that are hardly thicker than a human hair. The length of a coil winding can be as long as 4 km. The materials for the moulding vary corresponding to the capacity and the required chemical resistance. Every production step is followed by an automatic function check of all coils.

Our high vertical diversification enables the manufacture of customised coils to match the capacity and voltage requirements of your valve.



Mechanical production

Machining of metals and plastics at the Criesbach factory.

Our in-house machining technologies include:

- Milling
- Forming
- Welding
- Turning
- Injection moulding

Medical and analysis technology require high processing standards. We fulfil the different requirements for surface quality and media resistance by using suitable materials. Complex, customised forms are achieved in our in-house plastic injection moulding system. The machine park and in-house tool manufacturing department allow the manufacture of complex geometries. Our vertical diversification reduces production times and allows us to remain flexible for your application.

Guaranteed quality

Comprehensive inspections and tests ensure the quality of our products.

To fulfil your requirements we conduct numerous tests prior to starting serial production. International standards and directives are checked separately. Our UL lab, for example, is accredited as a test facility since 2014 and we have achieved "Category Certification Status" from CSA.

Once the requirements are fulfilled and the approvals are granted, valve production can begin. Our series start-up management provides for a smooth start-up of the production process. Not only our coils, but also the assembled valves go through a 100 % function check. Every valve delivered is tested and checked both electrically and mechanically. Nothing is left to chance.

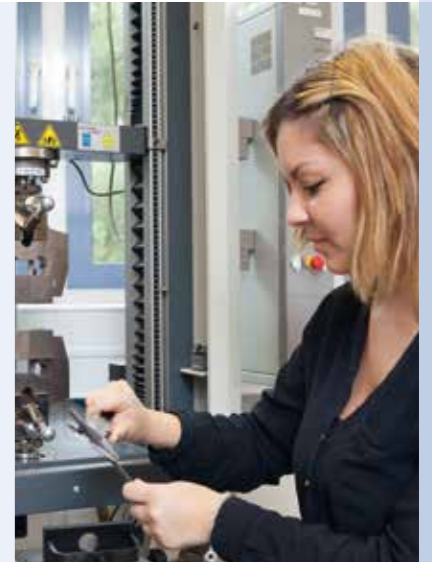

Dust-free environment

Special workplaces ensure clean assembly of miniaturised valves.

To guarantee the high quality and functionality of our products, valve assembly for sensitive applications takes place in a virtually dust-free environment. Filter systems in separate rooms minimise the particle concentration to ensure proper functioning of sensitive valves.

Some parts not only have to be dust-free, but also free of oils and greases. Special workplaces and cleaning processes make it possible to fulfil these hygiene conditions for our smallest valves.



Competent consulting

We can adapt everything to your needs, whether for a single valve or a special application.

We offer an extensive line of products that can be combined in many different ways. Together with you, thanks to many years of experience and the necessary know-how, we will find the right components and the optimal valve solution. Perfect coordination of all areas is your guarantee for the quality of our products.

In addition to our product line we also offer you comprehensive service to boost the performance of your processes.



MicroFluidics Characteristics

Gaining experience in the field of MicroFluidics since 1993, Bürkert is a competent partner of choice when it comes to devising solutions for the handling of even the tiniest volumes of liquids.

In order to meet the special demands derived from miniaturization and the particular area of application, the following criteria all form vital cornerstones in the development of new solutions:



Maximum Precision

In the world of microlitres, precision and reproducibility are an absolute must. Through innovative solutions and extremely precise manufacturing standards, Bürkert is able to meet the demand for both fast and reproducible response times as well as for long service lives of devices.



Excellent Cleanability

Particularly when handling biological media, cross contamination has to be prevented. Bürkert products offer excellent cleanability thanks to low dead volume design, optimized through-flow, as well as high-precision moulding.

Low Internal Volume

The more precious the resources are, the more efficiently they should be used. That is why Bürkert pays particular attention to minimizing the internal volume during the development of standard components and individual systems. This not only means that a system's cleanability is improved; it also maximizes the use of fluids flowing through the system.



Outstanding Chemical Resistance

No matter if it is for cell suspensions, acids or highly concentrated solvents, Bürkert has a solution at hand with a broad range of materials for a wide spectrum of applications. Our chemical laboratory works with application specialists and machine tool experts to guarantee an optimal choice even for critical applications.



Low Heat Transfer into the Medium

In order to avoid uncontrolled heat transfer into the medium, Bürkert rigidly keeps the solenoid and fluid chamber separate from each other. In addition, optionally integrated power-saving electronics can reduce the heat production.

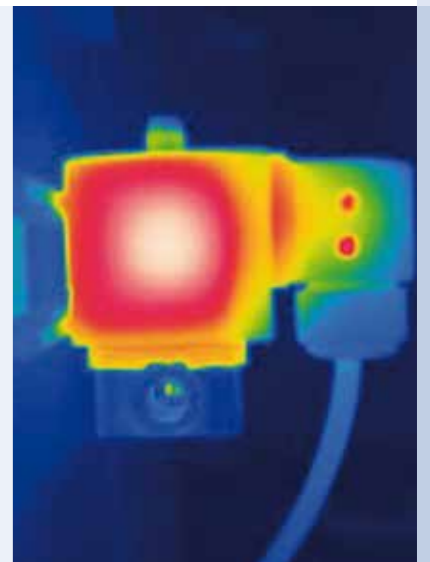

Accuracy, Precision and Timing

These are the criteria for reliable dosing. But how is accuracy, precision and timing achieved? There are several dosing principles in microfluidics, each with its own strengths and advantages. Knowing these strengths and the differences between each dosing principle is crucial in finding the correct one for your application. Follow our overview – we answer all your questions on dosing in microfluidics.

Time-Pressure Dosing
(Page 12)

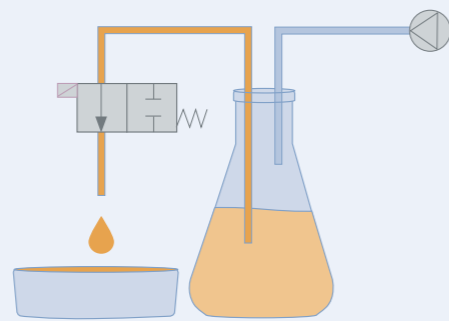

Syringe Pump Dosing
(Page 16)

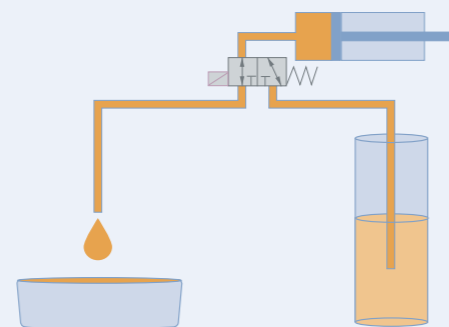

Volumetric Dosing
(Page 22)

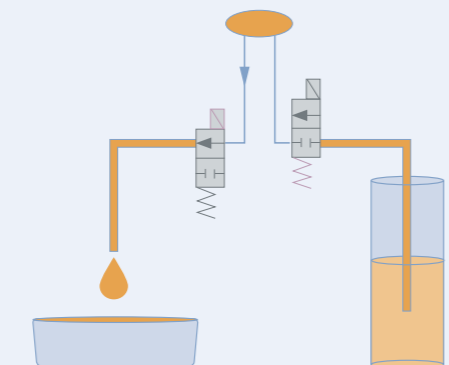

Reliability, Long Life Cycle and Efficiency

But it's not always about dosing for Bürkert. Many processes require fluid to be transported from a storage tank to its place of use. Our valves complete this task with flying colors. Whether it is aggressive or neutral media, high or low viscosity, the valves perform reliably and save you money, time and nerves.

Fluid Handling
(Page 26)

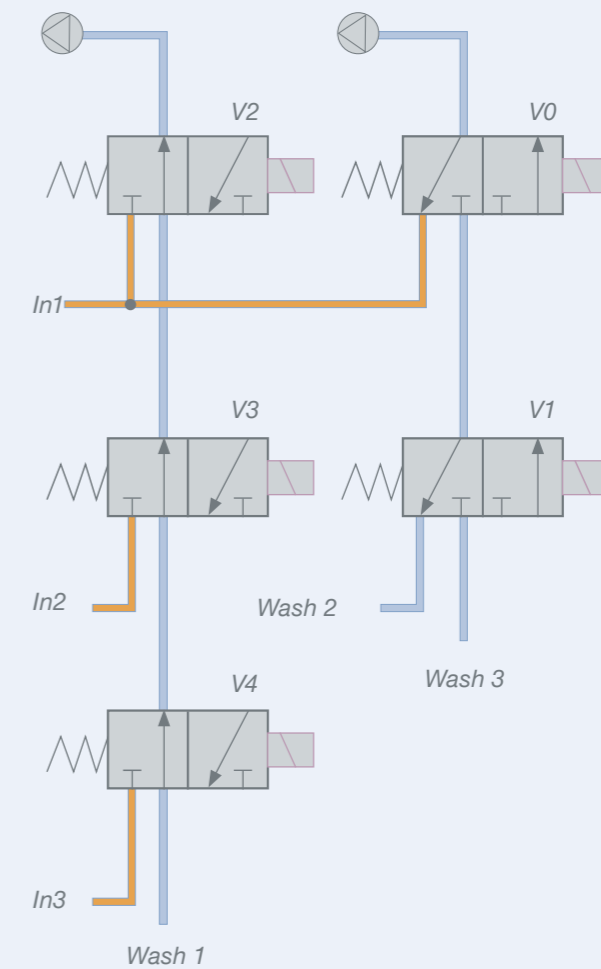

Time-Pressure Dosing

In time-pressure dosing the medium is stored in a pressurised tank and is carried through a valve to the dosing needle. Parameters such as tank pressure, flow resistance, product viscosity, and temperature of the medium are carefully controlled. The valve controls the flow of the medium by either opening or closing the stream of flow for a defined amount of time per switching cycle. Since the medium is driven by air pressure instead of a pumping mechanism, the process does not contain any mechanical moving parts in the stream of the medium.

High dosing velocity is combined with high dosing accuracy while also maintaining a high repeatability and reproducibility (low CV - coefficient of variation). Time-pressure dosing provides a degree of freedom as dosing amounts are individually adjustable. This is a great process for continuous dosing as required in applications such as process filling or vending.

Bürkert provides a wide range of products perfect for time-pressure dosing. With fast switching, low internal volume, excellent flushability, extremely high life cycle, and compact size, Bürkert valves are essential to any dosing application. Besides individual products, Bürkert has the know-how and experience in system solutions custom to any unique process. Let us support you in developing a customised system solution that completes your entire time-pressure dosing process.

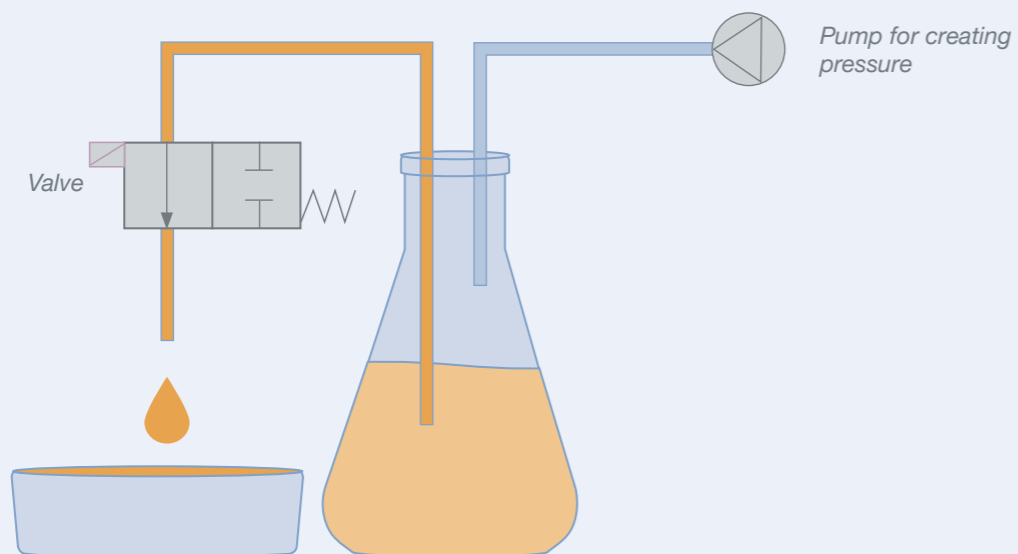

Applications using Time-Pressure Dosing

Process Filling

Whether it's the production of pills, filling of contact lens solution or dosing of jelly on cookies, time-pressure dosing provides the value that counts in process filling.

- Accuracy for reliable production
- High repeatability for the exact same dose, each time
- Fast dosing for a high speed production process
- Dosing volume is adjustable with the time parameter, providing flexibility for an easy, fast and cost-effective retooling process.



Vending

When it comes to your favourite drink, the exact combination of flavours is imperative.

- Precise mixing of flavour syrups in each drink
- High reproducibility so that each of your drinks tastes just as delicious as the first one
- Fast dosing so you can quench your thirst in seconds



Lab Analysis

Fast and reliable results are essential for correct doctor treatment and patient safety.

- Precise and accurate dosing of reagents and samples even of microliter volumes
- High reproducibility for reliable and comparable results
- High speed dosing for fast analysis especially in emergency situations



Products for Time-Pressure Dosing



Type 6650 – Flipper valve

With a width of just 4.5 mm, Type 6650 sets new industry standards. Along with its compact design, the 6650's extremely fast and high-precision switching makes it ideal for dosing tasks in the microliter range (3 µl with CV of < 3 %). Further advantages of the valve are its capability to handle pressures up to 7 bar (101 psi) for more flexibility of use in various applications. With a service life of up to 200 million cycles at 4.5 bar, it gives you more reliability.



Type 6712 – WhisperValve – plunger type with diaphragm

With its compact size (7mm width and 26 mm height), the media separated diaphragm valve Type 6712, WhisperValve, is ideal for integration in small, portable machines or on pipetting arms. Its low switching noise of <36 dB, allows for maximum concentration in the work place and optimal conditions for point-of-care applications. Fast switching guarantees precision dosing in any application. The low internal volume of only 5µl and excellent flushability, eliminates chance of cross contamination and guarantees reliable results.



Type 6144 – Flipper valve

The medium separated Type 6144 has been designed for general purpose use and is especially suitable in pneumatic applications. Its compact form leaves you more room for your innovations. The valve boasts a particularly long service life of more than 500 million cycles for greater reliability. It can be applied in many different applications thanks to its ability to handle pressures of up to 10 bar (145 psi). It offers more options with an available latching version or with explosion protection type Ex-ia.



Type 0331 – Pivoted armature valve

Type 0331 is especially suitable for the control of aggressive or waste media, which require a separation of medium and actuator. Depending on the orifice, the valve is suitable for pressures up to 16 bar (232 psi), and an orifice of up to 5 mm allows for high flow rates.

Complete System Solutions for Time-Pressure Dosing

Beyond standard products, we design an entire process including components such as pressure control, calibration, and system communication. Bürkert's competence and knowledge in customised system solutions allow us to provide you with the complete dosing process from the feed to the dispensing systems. Let us develop your dosing process together with you and we will provide you with an entirely developed, manufactured, assembled and tested system customised to your unique application.

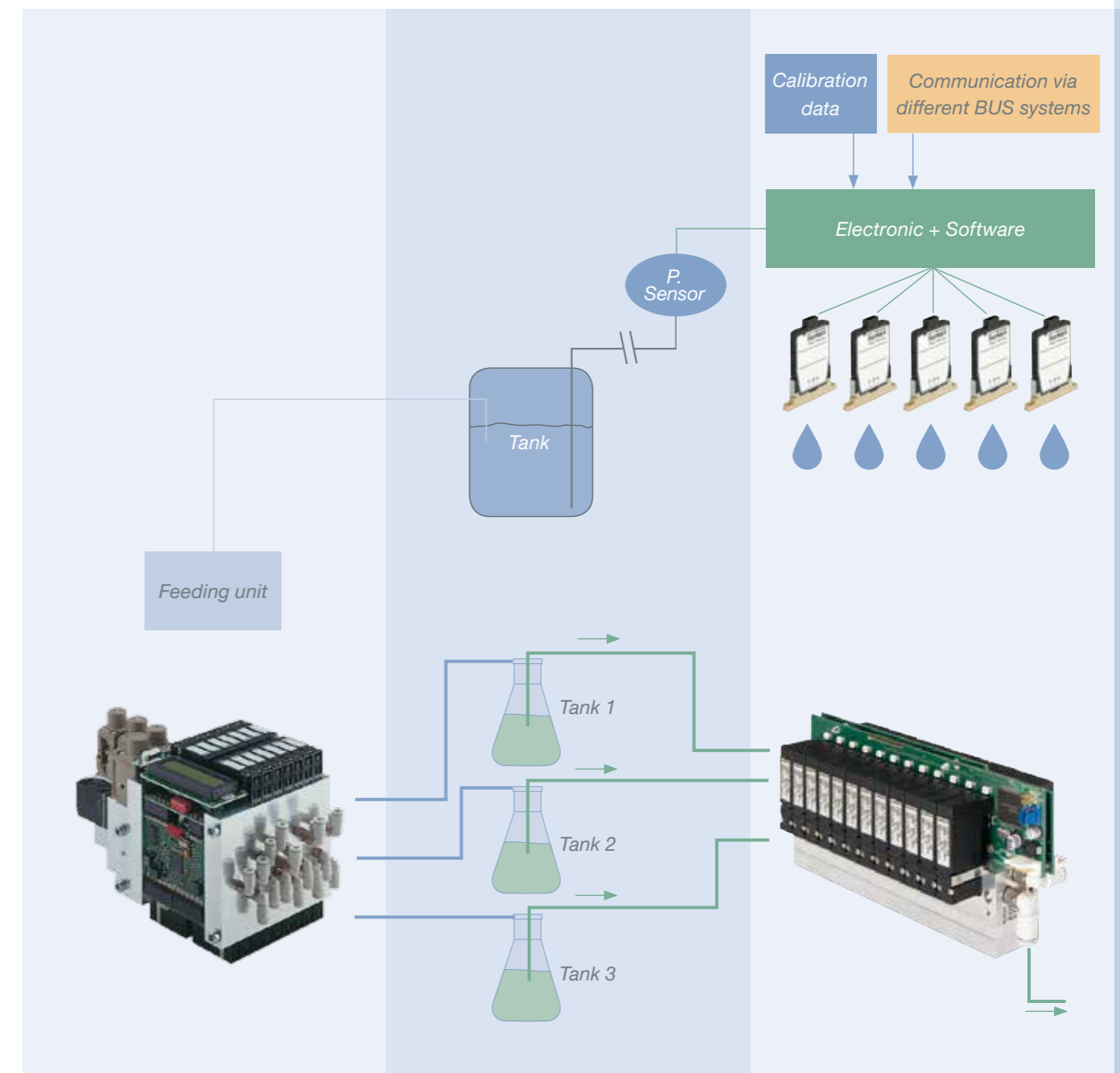

Syringe Pump Dosing

Syringe pumps make the exact dosing of small, specific fluid volumes possible. With the motion of a piston inside of the pump cylinder, medium is taken in through suction and dispensed back again. This principle works discontinuously. The pump takes a certain amount of liquid in through suction and dispenses it through the same channel to a needle again.

If medium is to be dosed from a container to a cuvette, a 3/2-way valve, which opens both inlet and outlet, must be positioned before the pump. In this set-up, the medium flows through both the valve and the pump. The cleaning is done analogous to the dosing of the medium.

Bürkert's expertise in precision dosing with ultra-short response times, low internal volumes, chemically inert materials for unaltered test results as well as cross contamination free components and manifolds all aid in effective design of your lab automation devices. A wide range of micro valves with different valve principles, with or without media separation, is available and perfectly suitable for syringe pump dosing. The valves all have excellent flushing ability, which is very important since the medium flows through both the valve and the pump; any residue would impair the excellence of the dosing process.

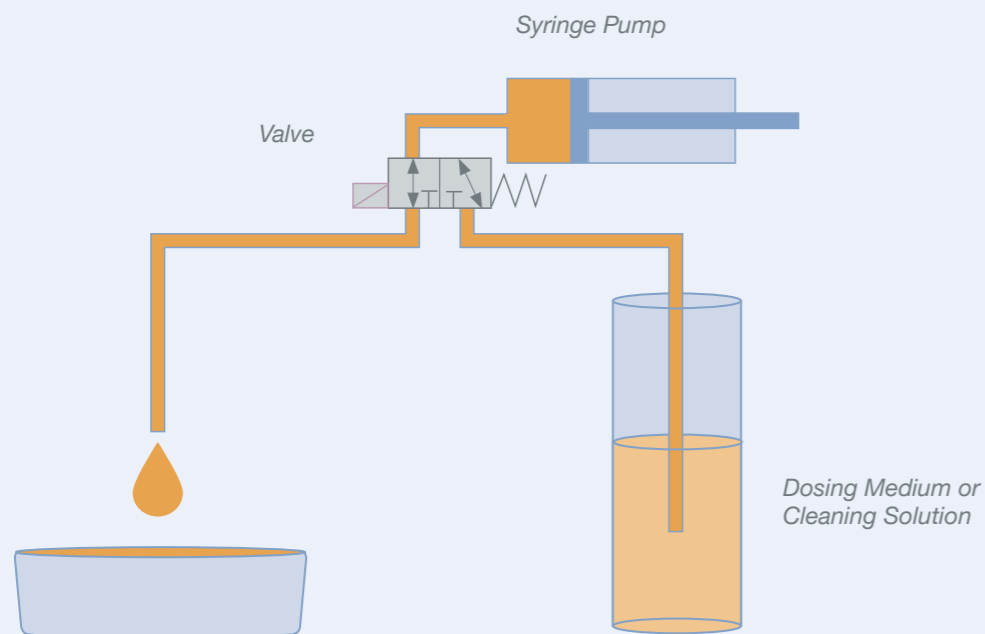

Air Isolated Syringe Pump Dosing

This dosing principle also uses a syringe pump. However, the medium is not sucked into the pump, just into a dosing needle. This method is used above all in applications with very low dosing amounts. An isolating air pocket acting as a barrier is both in the syringe pump as well as in the inlet channel. The medium only comes into contact with the dosing tip, due to the isolating air pocket. This way, the risk of contamination is minimised. This principle makes an integrated cleaning of the dosing tip possible. After the medium is dosed, a valve opens the cleaning channel. The cleaning solution, which is stored under pressure, flows only through the dosing tip and the syringe pump remains free of liquids, even during the cleaning process, thanks to the isolating air pocket.

Blood, serum and urine analysis require expertise in sample and reagent handling, flushing and waste treatment. As your established partner, we can optimise integration of specific system solutions for mixing, distribution or dosing.

Bürkert customised system solutions and products have proven to be excellent process components in Air Isolated Syringe Pump Dosing. The cleaning process is perfected with both custom systems as well as media separated valves, supported by a range of chemically resistant materials.

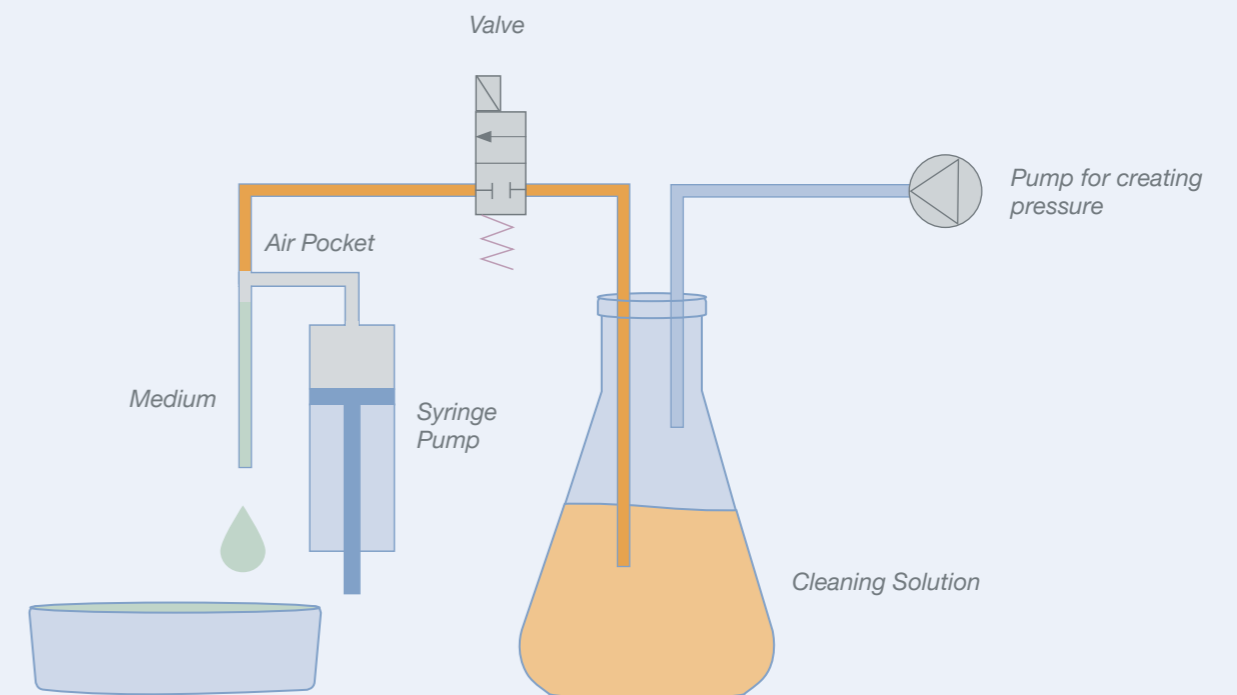

Applications using Syringe Pump Dosing



In-Vitro Diagnostic

In-Vitro Diagnostic involves the testing of different parts of the blood and is the basis of physicians' therapies for patients like you and me. Syringe Pump Dosing:

- Fits the high automation of the analysis machines.
- Makes precise dosing of microliter fluid amounts possible.
- Fits the goal to reduce human interaction with the system to a minimum.
- Minimises the chance of contamination thanks to the air pocket in Air Isolated Syringe Pump Dosing, which requires only flushing of the dosing needle.



Molecular Diagnostics

Patient therapy can also be determined and designed based on the results of molecular diagnostics. Molecular Diagnostics is the analysis of the human genetic code, used in areas such as prenatal testing, infectious disease detection and disease risk management. Syringe Pump Dosing:

- Guarantees precise control of reactants, testing samples, and cleaning solution to ensure accurate results.
- Is a dependable process for reliable testing and diagnosis with minimal chance of contamination.



Products for Syringe Pump Dosing



Type 6724 – Rocker WhisperValve

Type 6724 is the larger version of the WhisperValve Type 6712 (9 mm width, 43 mm height, and 1,2 mm orifice). A membrane separates the fluid chamber from the actuator and allows the use of aggressive media. With the nearly silent switching, it is perfect for the laboratory and medical applications providing a quiet environment at the patient's side. The low internal volume of 29 µl, excellent flushability and precision dosing guarantee reliable testing results.



Type 0127 – Rocker valve

The pioneer of media-separated valves sets the standard in the field of laboratory, medical and analytical devices since 1993. This valve combines low internal volume for less unused fluid medium, with less chance of contamination thanks to its minimal dead volume. You have more flexibility with a large variety of port connections and materials.



Type 6624 – TwinPower Rocker valve

The new TwinPower actuator enables a radical reduction in size and footprint, for more flexibility in positioning while saving space for your innovations, without compromise in performance. With only 10 mm pitch, our media-separated rocker valve comes along with 1.6 mm orifice and 2 bar (29 psi) pressure resistance – the same performance data as the traditional, larger 16 mm rocker valve.



Type 6626 – TwinPower Rocker valve

The Type 6626 is the bigger counterpart of Type 6624, using the TwinPower actuator as well. With pressures ranging from vacuum to 2 bar (29 psi) and an orifice of 3 mm, this technology allows for a valve with only 16 mm in width increasing the size-to-performance ratio leaving you with more power and more space for your own innovations. An additional LED enables the status monitoring of the valve giving you more control and reliability.



Type 6628 – Rocker valve

The 22 mm valve complements the TwinPower family by using the same fluidic design as the proven and reliable Type 0127. The established rocker technology is characterised through its reliable sealing of the valve seat with full back pressure tightness. Cross contamination is eliminated with its good rinsing capability, and the low internal volume maximises the use of medium. Type 6628 is available with different port connections, sealing and housing materials for adaptation to various applications.

Complete System Solutions for Syringe Pump Dosing

Bürkert's willingness to listen carefully and to respond by developing a solution in accordance with the exact requirements enables you to concentrate on your tasks.

For precise and reliable measurement, regulation and control of the flow rates in an analytical instrument, Bürkert developed a unique modular system. The used valves feature our rocker technology, which ensures not only a complete back pressure tightness, good flushability and a low internal volume, but also precise switching of micro volumes with minimal temperature rise through the coil.



An essential function in blood analysis is the detection and prevention of air bubbles, which can substantially corrupt the results of the analysis. Bürkert therefore avoided rough surfaces, dead zones and sharp edges in the design of the dosing unit. A special challenge was the customer's requirement for a transparent window for visual inspection, to be placed in front of the dosing unit and beneath the structure with the valves and pressure sensor. Bürkert developed an injection moulded part with a very high surface quality and no sharp edges in the area of the dosing unit.

The new one-for-all dosing unit can now be used in more than one analysis device.

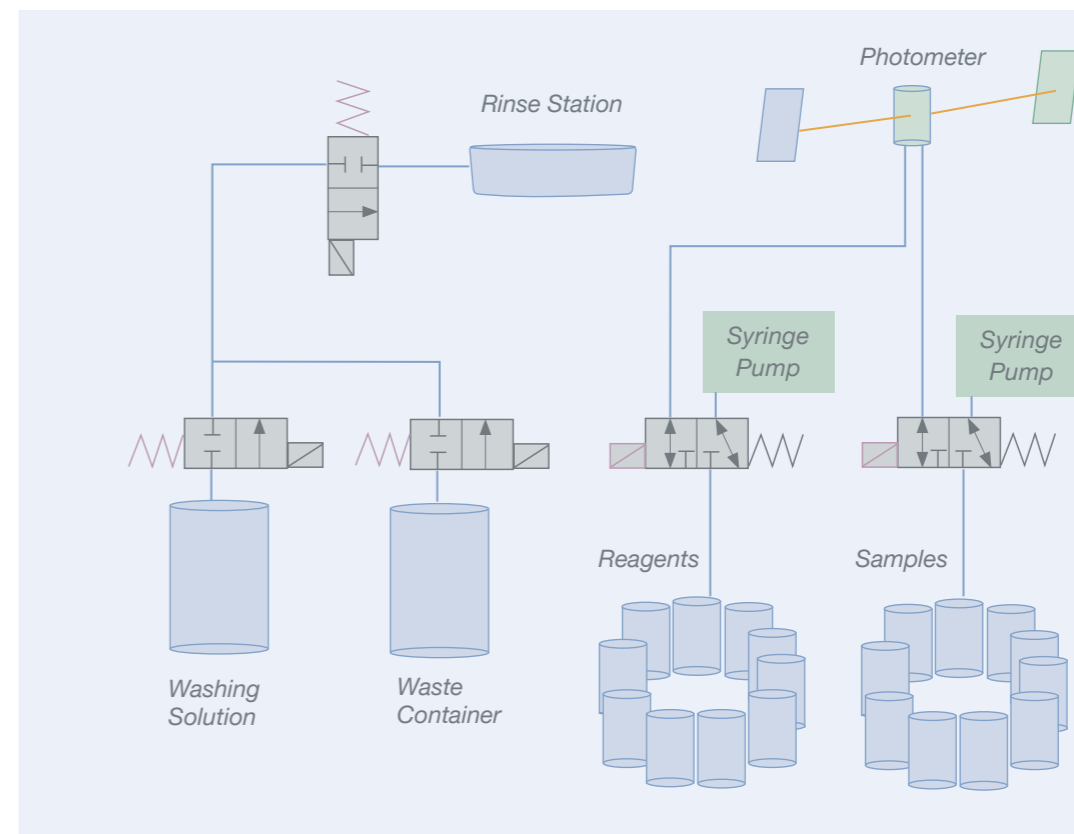

Volumetric Dosing

In volumetric dosing, an accurately defined dosing amount is dispensed with each stroke of the pump. This individual stroke volume cannot be adjusted, however the number of strokes can vary the dosing amount. The principle is excellent for continuous dosing. A high dosing velocity makes volumetric dosing valuable in many applications such as Vending and Pharmaceutical Dosing.

Bürkert not only supplies valves perfectly suitable for volumetric dosing, but we also apply this dosing principle to several of our products, the micro pumps. Whether operated with pressure and vacuum or by integrated solenoid valves, Bürkert micro pumps integrate the entire volumetric dosing principle in a single compact product. Used for precision dosing in many applications, Bürkert products support your process with accuracy and reliability.

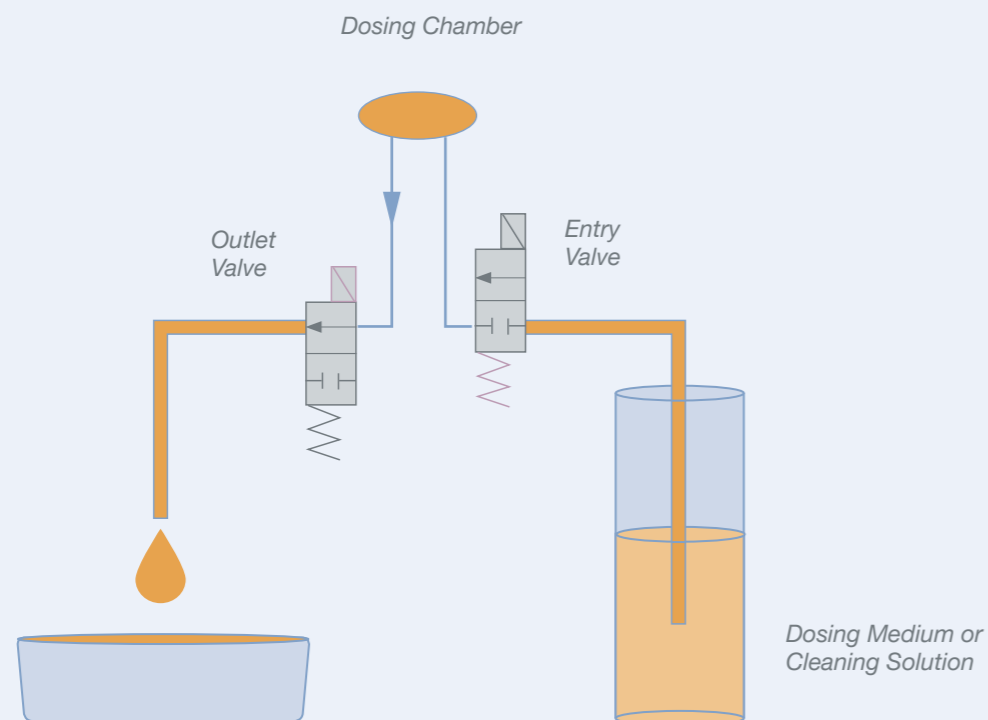

Applications using Volumetric Dosing

Vending

To achieve the perfect drink, even the smallest dose of flavour syrup can affect the taste. The accurate dosing and mixing of flavours is essential in vending.

Volumetric dosing:

- Enables the dosing of even the smallest fluid amount.
- Guarantees accurate dosing independent of the viscosity of the flavour syrup.
- Makes immediate dispensing possible with high speed dosing.

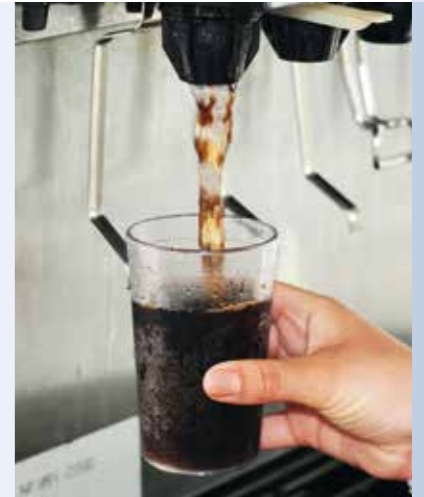

Dosing of Adhesives & Lubricants

The dosing of adhesives and lubricants means dosing under a wide range of conditions such as different viscosities and temperatures of the medium.

Volumetric Dosing:

- Provides accuracy independent of medium viscosity and temperature.
- Guarantees reproducibility and repeatability of precise dosing amounts even in the microliter range thanks to the calibrated dosing chamber.



Pharmaceutical Dosing

In pharma, precision and accuracy are imperative because the processes are always connected to a life.

Volumetric Dosing:

- Provides accurate dosing with each stroke of the pump thanks to the exactly calibrated dosing volume.
- Guarantees high repeatability and reproducibility for a reliable pharma process.
- Can be realised with disposable dosing chamber to reduce chance of contamination.



Products for Volumetric Dosing



Type 7604 – One directional pump

The self-priming diaphragm pump is ideal for continuous low flow liquid applications and provides a plug-and-play solution without cumbersome start-ups. Since only the high-class materials PEEK and FFKM get in contact with the fluid, the pump can also be used for aggressive chemicals. The mounting pitch of 11 mm allows for an extremely compact design and ease of mounting, with standard bodies designed for surface mount (manifold) or tube connections. The low power consumption of just 1.5 watt means the pump can be easily incorporated into battery-powered mobile devices. The flow rate can be adjusted by varying the frequency input to fit your specific performance requirements. Due to the high maximum frequency of 40 Hz, the pulsation is reduced to a minimum, maximising accuracy.



Type 7615 – Bidirectional pump

The Micro Dosing Unit 7615 consists of a diaphragm pump and active inlet and outlet valves. The components are assembled on a manifold in order to keep the internal volume to a minimum. The delivered volume can be adjusted via the cycle rate for more flexibility. Thanks to its high reproducibility ($< \pm 2\%$), the unit is ideal for precise dosing of the smallest quantities of liquids and guarantees high quality test results. PEEK and FFKM are the only materials that come into contact with the medium. This facilitates the use of aggressive media. The Micro Dosing Unit can be easily connected via a 4-pole plug. It has an integrated electronics for an immediate use.

Complete System Solutions for Volumetric Dosing

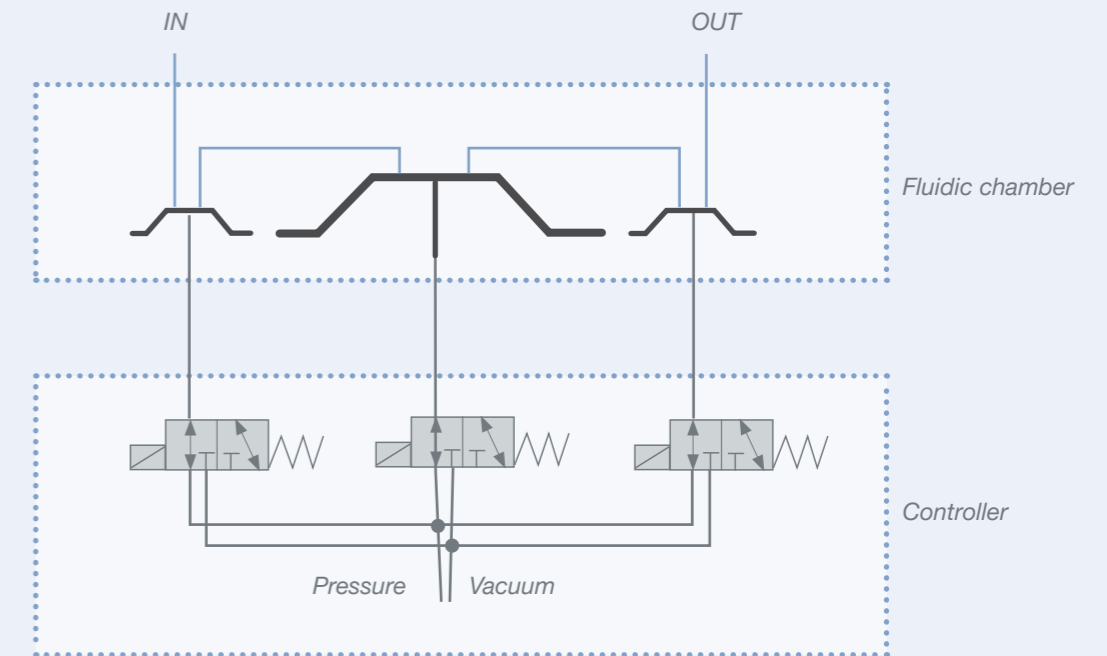

Pneumatic Dosing System

With the combination of a compact fluid chamber and an integrated control unit for pressure and vacuum, Bürkert designed a truly unique dosing system customisable to your application. It's installed in the blink of an eye thanks to easy plug-and-play capabilities.

- Precisely defined and calibrated dosing volume per stroke of the system
- High dosing velocity adjustable to the application
- Highly chemically resistant material for dosing of aggressive media
- Compact size for excellent system integration
- Easy combination for multiple dosing stations in the process



Fluid Handling

When it comes to fluid control of small volumes, there are various solutions depending on the application. Let us take on your challenge: from water analysis to dental chairs, from ink jet printing to dialysis –We serve a wide range of applications with the common demand for high-performance fluidic components. You have our guarantee for cleanability, durability and reliability. Whenever you set the highest quality requirements for your flow, we are on board.

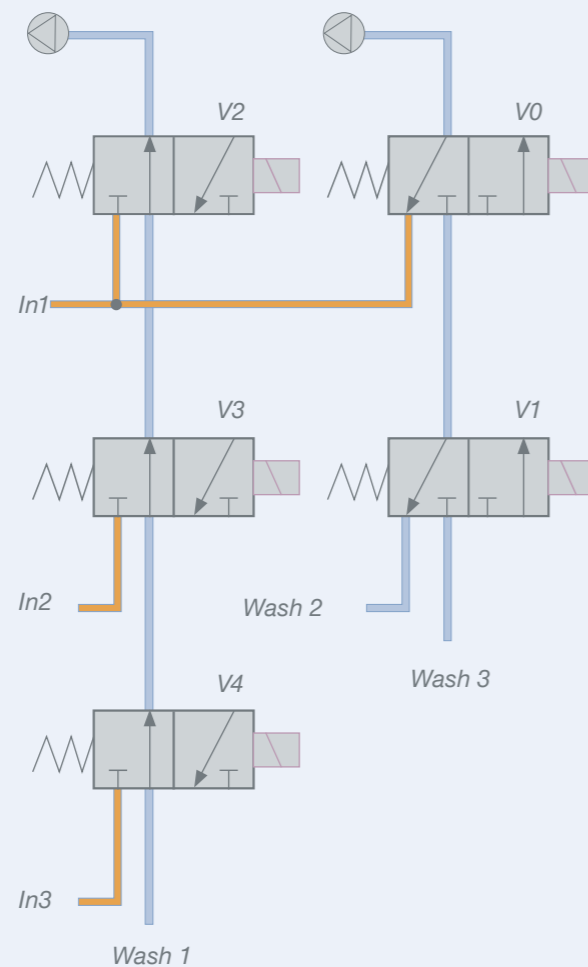

Fluid Handling Applications

Medical Technology

From dialysis to endoscope cleaning to the dental chair, our products are used daily, in service of patients and users.

- Bürkert products undergo 100% testing before leaving our facilities.
- Jointly developed risk analyses offer users and patients the secure feeling of being in good hands.



Inkjet Printing

We have reached a point in time, in which we can print on almost any surface we desire. Industrial inkjet printing offers an array of printing and design possibilities for any surface.

- Chemical resistance and long life cycle are factors that our products have mastered.
- Customised system solutions from Bürkert match your requirements in terms of design, documentation and logistics.



Water Analysis

Water is the source of life and its quality is essential for man and nature. To check this quality, the total organic carbon (TOC) is measured and Bürkert valves must not be excluded from this analysis process.

- Low maintenance thanks to high quality components.
- No carryover due to excellent flushability of the fluid chambers.



Products for your fluid control



Type 6724 – Rocker valve WhisperValve

Type 6724 is the result of the systematic innovation in dialogue with the customer. The low internal volume of just 29 microliter, the excellent flushability and highly precise dosing capabilities guarantee reliable results. A membrane separates the fluid channel from the actuator and thus makes the switching of aggressive media possible. With nearly silent switching noise, it is perfect for the use in medical applications providing a quiet environment at the patient's side.



Type 6628 – Rocker valve

The 22 mm valve complements the TwinPower family by using the same fluidic design as the proven and reliable Type 0127. The established rocker technology is characterised through its reliable sealing of the valve seat with full back pressure tightness. Cross contamination is eliminated with its good rinsing capability, and the low internal volume maximises the use of medium. Type 6628 is available with different port connections, sealing and housing materials for adaptation to various applications.



Type 0117 - Plunger valve

Type 0117 combines the classic plunger technology for solenoid valves with a separating membrane, which convinces with a PTFE coating. The membrane makes the switching of chemically aggressive media possible, without damaging the valve.



Type 6011 - Plunger valve

In those cases when media separation is not necessary, but the reliable operation is still required, that is when Type 6011 is at home. This product is your trusted worker, completing its tasks quietly but reliably in the background.

Complete confidence in safe solutions

Smoothly functioning technology is essential for both doctors and patients. This means that the treatment units must fulfill very stringent requirements and must be designed for reliable, safe, hygienic, quiet and unobtrusive operation. The challenge is to constantly develop and adapt the technology to the changing needs and requirements of dentists and their patients.

All requirements fulfilled: For all media input components KaVo puts its trust in Bürkert's special system competence and expertise. Bürkert supplies the entire water and air block for the dental treatment units. These are supplemented by other components, assemblies, spare parts and maintenance sets. The current system solutions for the air and water block were already developed about 20 years ago in cooperation between Bürkert and the customer, and the solutions are continuously being optimised.



You always benefit from our system competence:



Everything from a single source:

Comprehensive system competence for well thought-out solutions



Safety in development:

Perfect understanding of all product requirements



Short implementation times:

Close cooperation saves time during development



Increased flexibility:

Short response time of the in-house Kanban warehouse to meet rising demands



Reliable quality:

Based on 30 years of joint experience in the applications

Flipper Valves

The core component in flipper valves is a metal lid vulcanized with elastomer. This pivoting "flipper" is housed in the fluid chamber and alternately closes one of the two valve seats.

As in valves with diaphragms, flipper valves provide a complete separation of medium and actuator. However, the switching action of the flipper creates no pump effect. In addition, the flipper valve technology allows for especially short and reproducible response times and an extended service life due to the lack of diaphragm flexing.

This makes this technology particularly suitable for precise dosing applications. Since the medium does not act on large areas of a diaphragm, flipper valves remain tight even at back pressures above the nominal pressure.

Characteristics:

- short and reproducible response times
- no pulsation
- low power consumption
- enclosed fluid chamber

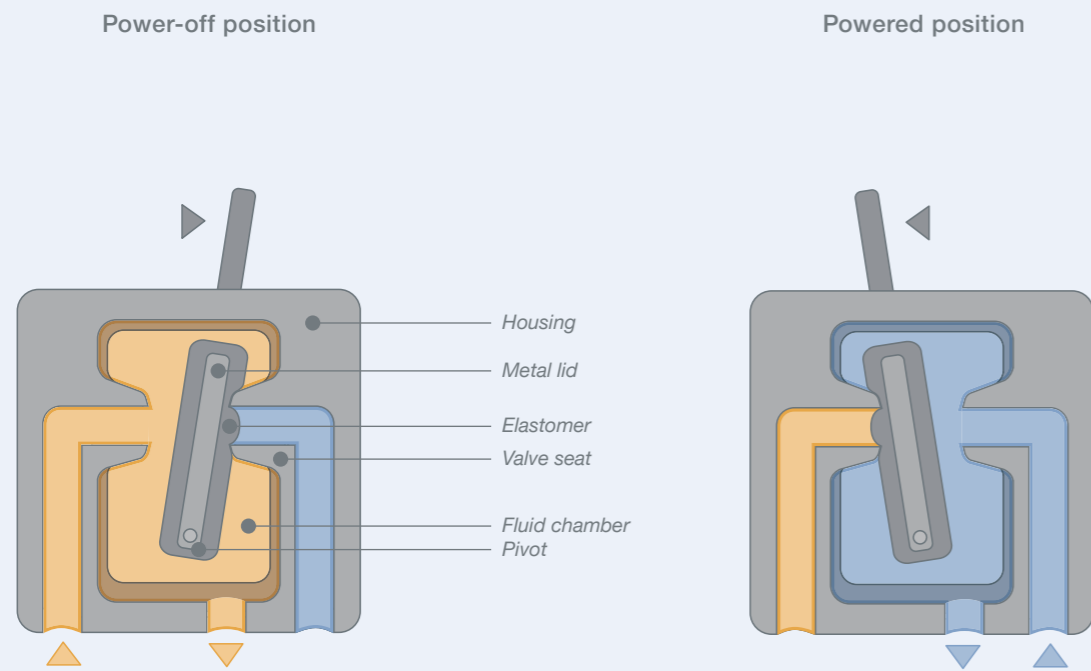

3/2-way valve flipper technology

Rocker Valves

The valve seats in rocker valves are in one plane and opened and closed by a switching rocker. Due to the extremely small amount of moving mass involved, the distinguishing feature of rocker valves is their particularly long service life.

Alongside the non-media-separated valves for pneumatic applications, the principle behind rocker valves also allows for the reliable separation of medium and actuator by way of a diaphragm. In contrast to plunger type valves with a diaphragm, the construction principle of rocker

valves provides a secure seal of the valve seats even if a high back pressure is applied. Due to the lack of gaps in the inner contour and the very good cleanability of the fluid chamber, the media-separated rocker valves are particularly well suited for use with biological media.

Characteristics:

- excellent cleanability
- minimal internal volume
- high back pressure tightness
- media separated from actuator

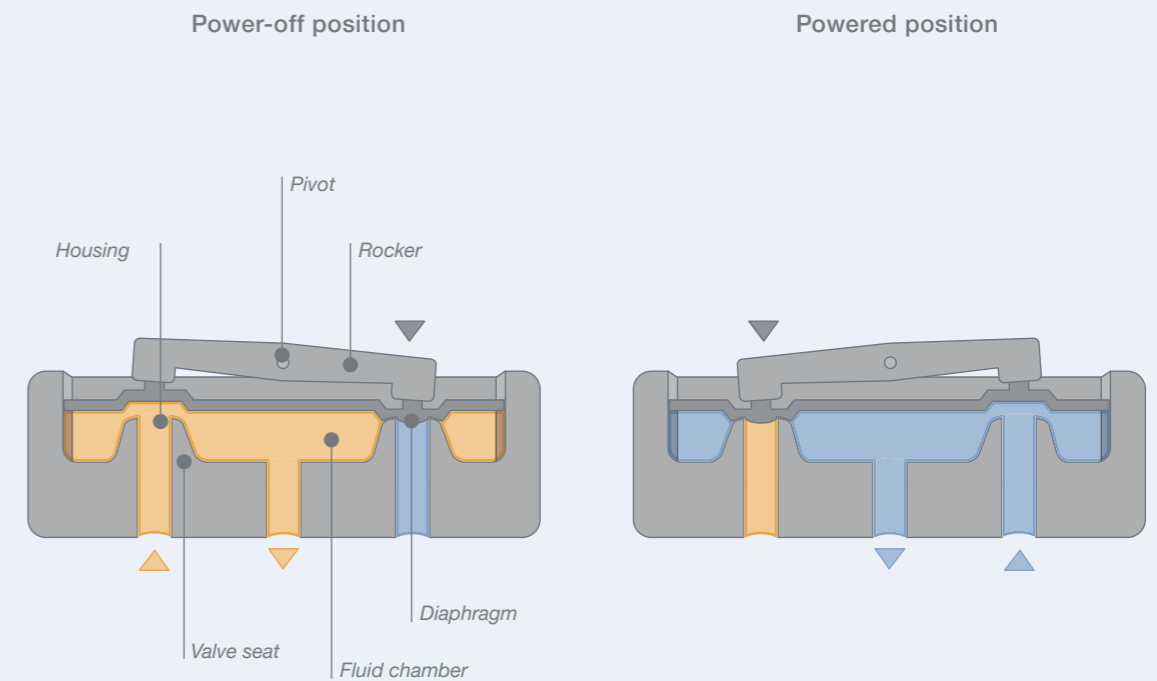

3/2-way valve rocker technology

Plunger Valves

The main components of this valve type are a coil, a closing spring, a valve body cover and the valve body with the seat. Without current the path to the outlet is blocked (normally closed), since the closing spring presses the plunger onto the valve seat. If current flows through the coil, the latter generates a starting force, which pulls the plunger and the seal against the spring force and draws the medium upward. The channel is opened for the medium.

With a media separating membrane, the valves are used for the control of gases and fluids in analytical applica-

tions. They are ideal for switching aggressive and high purity media, since the separating diaphragm ensures a hermetically sealed coil and only high-quality plastics are used as the sealing and body material.

Characteristics:

- Long service life
- High pressure and temperature ranges
- Increased switching cycles

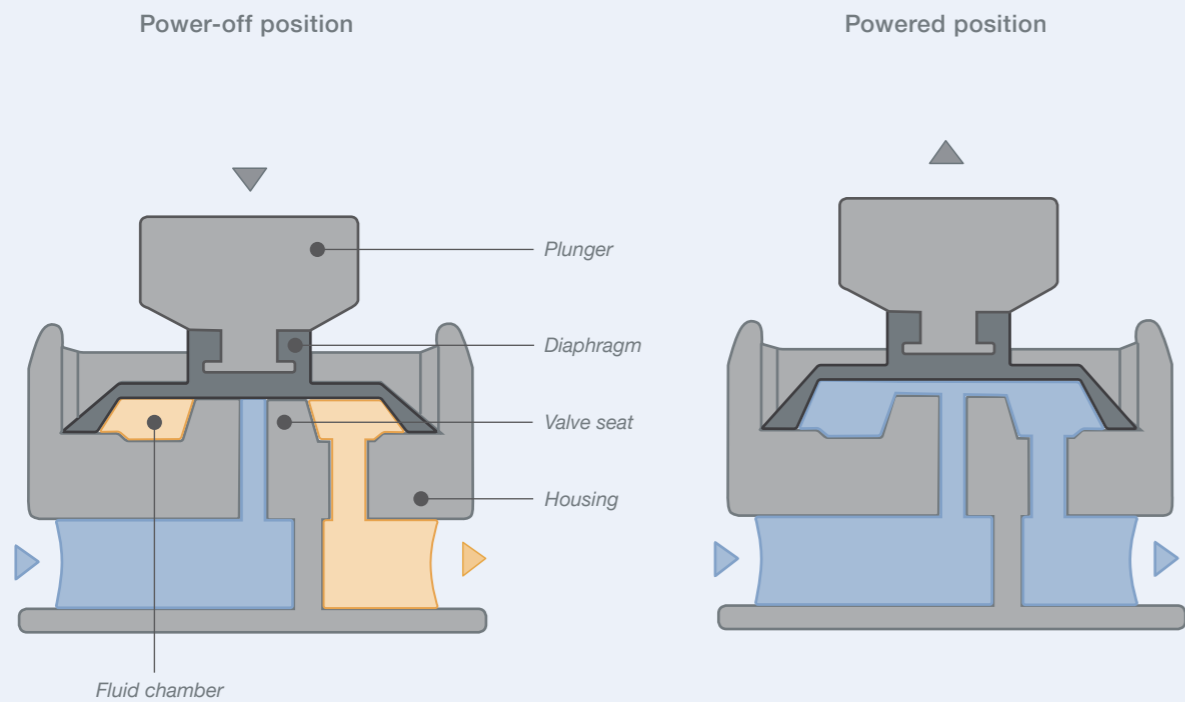

2/2-way valve plunger technology

Product Selection Chart

Installation width	Orifice	Max. pressure in bar													
		Vac	1	1.5	2	3	4	5	6	7	8	9	10	11	12
		Max. pressure in psi													
		Vac	14.5	21.7	29	43.5	58	72.5	87	101.5	116	130.5	145	159.5	174
4.5 mm	0.4 mm	6650													
	0.8 mm	6650													
7 mm	0.4 mm	6712													
	0.8 mm	6712													
9 mm	0.8 mm	6724													
	1.2 mm	6724													
10 mm	0.5 mm	6164													
	0.6 mm	6144													
	0.8 mm	6624*													
	1.2 mm	6164													
11 mm	0.8 mm	6164													
	1.0 mm	6164													
16 mm	0.8 mm	0127*													
	0.9 mm	6106													
	1.0 mm	0127*													
	1.2 mm	6106 0127*													
	1.6 mm	6106 0127*													
	2.0 mm	6626* 6106													
20 mm	1.2 mm	0117													
	1.6 mm	0117													
22 mm	2.0 mm	0117													
	2.4 mm	0117													
22 mm	2.0 mm	6628													
	3.0 mm	6628													
32 mm	2.0 mm	0330 0121													
	3.0 mm	0330 0121													
	4.0 mm	0330 0121													
	6.0 mm	0121													
	8.0 mm	0121													

* Maximum differential pressure: 2 bar | 29 psi
 Vac = Vacuum
 The pressure ranges are dependent on the circuit function, power supply and materials.

Bürkert Systemhaus – Your ideas at home

With our dedicated world-class engineers and our superlative manufacturing facilities we can deliver systems, which meet your exact requirements. Bürkert's Systemhaus team members are flexible, open minded and experienced. They have the ability to listen and communicate in your language to design your customised solution.

CAD-created animations or simulations, combined with rapid prototyping, material selection, tool design, construction, and assembly knowledge enable us to provide a production concept for your system at an early stage.

Your designated project team starts working for you: from your reliable sales consultant, qualified industry specialists to dedicated system engineers – Bürkert puts the necessary experts together for you.



Systemhaus Ingelfingen, Germany



Systemhaus Dortmund, Germany



Systemhaus Dresden, Germany



Systemhaus Suzhou, China



Systemhaus Charlotte, USA

Bürkert – Close to You

For up-to-date addresses
please visit us at
www.burkert.com.

